



OPA 1370, 2000 Commissioning Sheet

Form NS 228
Issue 1, December 2011

Start Up Date Installing Company

Contract Name Model No./ Serial No. /

REFRIGERATION

	(If applicable)			
	System 1	System 2	System 3	System 4
Refrigerant type				
Refrigerant added on site per system, if required (kg)				
Superheat (°C)				
Suction pressure/Discharge pressure on Cooling (kPag)	/	/	/	/
Suction pressure/Discharge pressure on Heating (kPag)	/	/	/	/
Discharge pipe temperature: Heating / Cooling (°C)	/	/	/	/
Refrigerant leak check ?	YES / NO	YES / NO	YES / NO	YES / NO

ELECTRICAL

Supply voltage				
Compressor drawn amps				
Overload setting				
Compare published compressor amps				
Outdoor fan motor amps drawn				
Indoor air fan motor amps drawn				
Boost heater element amps drawn				
Total Unit amps drawn				
Thermostat setting (°C)				
Thermostat operating correctly ?		YES / NO		
Contactors & relays operating correctly ?		YES / NO		
All terminals checked for tightness and label signed ?		YES / NO		

TEMPERATURES

Outside ambient temperature (°C)	
Indoor Unit air temperature On / Off on Heating (°C)	/
Indoor Unit air temperature On / Off on Cooling (°C)	/

DUCTING

Total Return air flow (Total of all inlets) (l/s)	
Total System external resistance (Pa) *	
Estimate of Fresh Air Make-Up (% or l/s)	

* Total of external resistances measured downstream of fan outlets plus upstream of coil(s)

GENERAL

Air filters: overall size and number	
Drain pipe traps and vents fitted as per Installation Instructions?	YES / NO
Drain is clearing water properly?	YES / NO
Check vibration of Outdoor Unit	OK / EXCESSIVE
Pulley and/or Belt change (if applicable)	
Belt tensioning adjusted (if applicable) ?	YES / NO
Removed compressor shipping blocks?	YES / NO
Paint finish checked and repaired?	YES / NO

PULLEY ADJUSTMENT & BELT TENSIONING: Refer to instructions overleaf

SIGNED : Commissioning Engineer

**NOTE: This sheet to be completed and returned to temperzone and a copy retained for your files.
Failure to record and complete the above information may affect unit warranty.**

Variable Pitch/Speed Pulleys Adjustment Guide

To adjust *single groove* variable pitch pulley:-

1. Loosen three locking grub screws
2. Rotate the movable flange anti-clockwise to reduce the pitch and slow the fan driven speed
3. Rotate the movable flange clockwise to increase the pitch and speed up the fan driven speed
4. One third of a turn (120°) varies the pitch circle diameter by 2.18 mm
5. Align the grub screws with the grooves, tighten each grub screw and apply a drop of "Loctite Blue 243"
6. Re-align the belts using the pulley faces as a guide, refer note and figure 2 below in troubleshooting guide
7. Apply a drop of "Loctite Blue 243" to grub screws when re-tightening on to the shaft and flat.

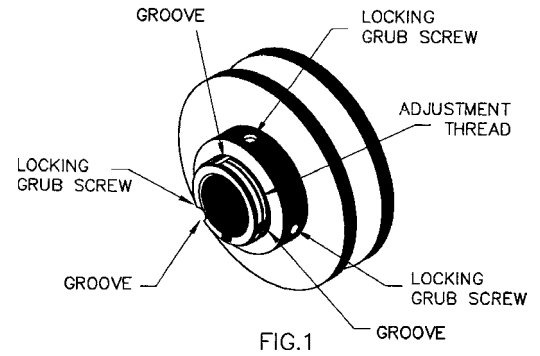

To adjust *double groove* variable pitch pulley:-

1. Mark both moveable flanges with an index mark
2. Loosen six locking grub screws (may be easier to loosen just three screws and adjust one side first then the other)
3. Rotate the movable flanges anti-clockwise to reduce the pitch and slow the fan driven speed
4. Rotate the movable flanges clockwise to increase the pitch and speed up the fan driven speed
5. One third of a turn (120°) varies the pitch circle diameters by 2.18 mm
6. Both moveable flanges must be adjusted equally (hence the index mark)
7. Align the grub screws with the grooves, tighten the grub screws and apply drop of "Loctite Blue 243"
8. Realign the belts using the pulley faces as a guide, refer note and figure 3 below in troubleshooting guide
9. Apply a drop of "Loctite Blue 243" to grub screws when re-tightening on to the shaft and flat

Variable Pitch/Speed Pulleys Troubleshooting Guide

Premature Belt Failure or Excessive Vibration

Be careful not to slow the fan down too much. Rotating the moveable flange anti-clockwise too far will "bottom" the belt and it will not sit properly in the groove. This will cause rough running and early belt failure. Also the moveable flange will only be held on by a thread or two. A minimum clearance of 6 mm is required between the bottom of the cog belt and the bottom of the pulley groove. See figures 2 and 3.

Poor Alignment of the Belts or Belts Squealing

Single and Double groove pulleys should be aligned using the outside faces, noting that the variable pitch pulley faces will most likely be wider than the standard fixed pulley, allowance should be made for this so that the belt/belts, is/are centralised (see figures 2 and 3). ENSURE MOTOR AND FAN SHAFTS ARE PARALLEL.

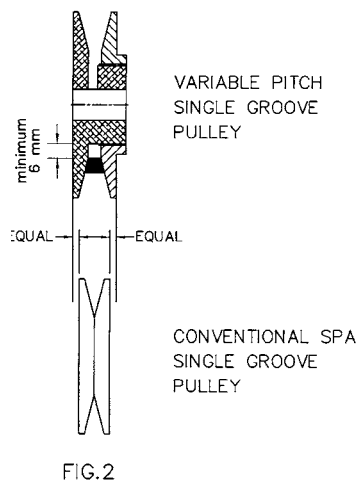

FIG.2

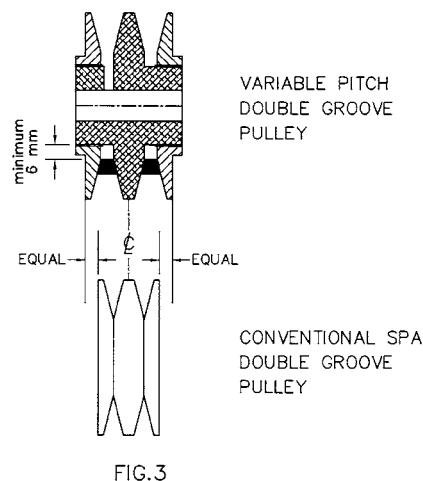

FIG.3

Belt Tensioning Guide

To Adjust a V-belt (Type SPA or XPA):

1. Measure the span length of the belt between the two pulleys
2. Calculate the required deflection at 1.5 mm per 100 mm span
3. Adjust belt tension until deflection is reached at the centre of the beltspan with 25N (2.5 kg) deflection force applied perpendicular to the belt (Note: Use a belt tension tester tool for the best results).
4. Belt tensioning should be finally checked and adjusted after 20–30 mins run time.

BEWARE! The main causes of premature belt failure or excessive wear are: incorrect alignment of pulleys, fan and motor shafts not parallel and incorrect belt tensioning.